



CASSELS BROCK  
LAWYERS



Len Glickman

# An Essential Piece: Protecting Your Intellectual Property — Creating a Strategy that is Right for You

March 31, 2010

# Intellectual Property Framework for Fashion Companies in Canada



- Trade-marks
- Copyrights
- Industrial Designs
- Patents
- Trade Secrets
- Trade Dress
- Domain Names

# Importance of Intellectual Property



## 1. Protection

- Prevent unauthorized copying.
- Associate your brand with your garments.

## 2. Exploitation

- Sell, assign, license, and use as an asset to negotiate funding or investment.

# Who's in Charge in Canada?

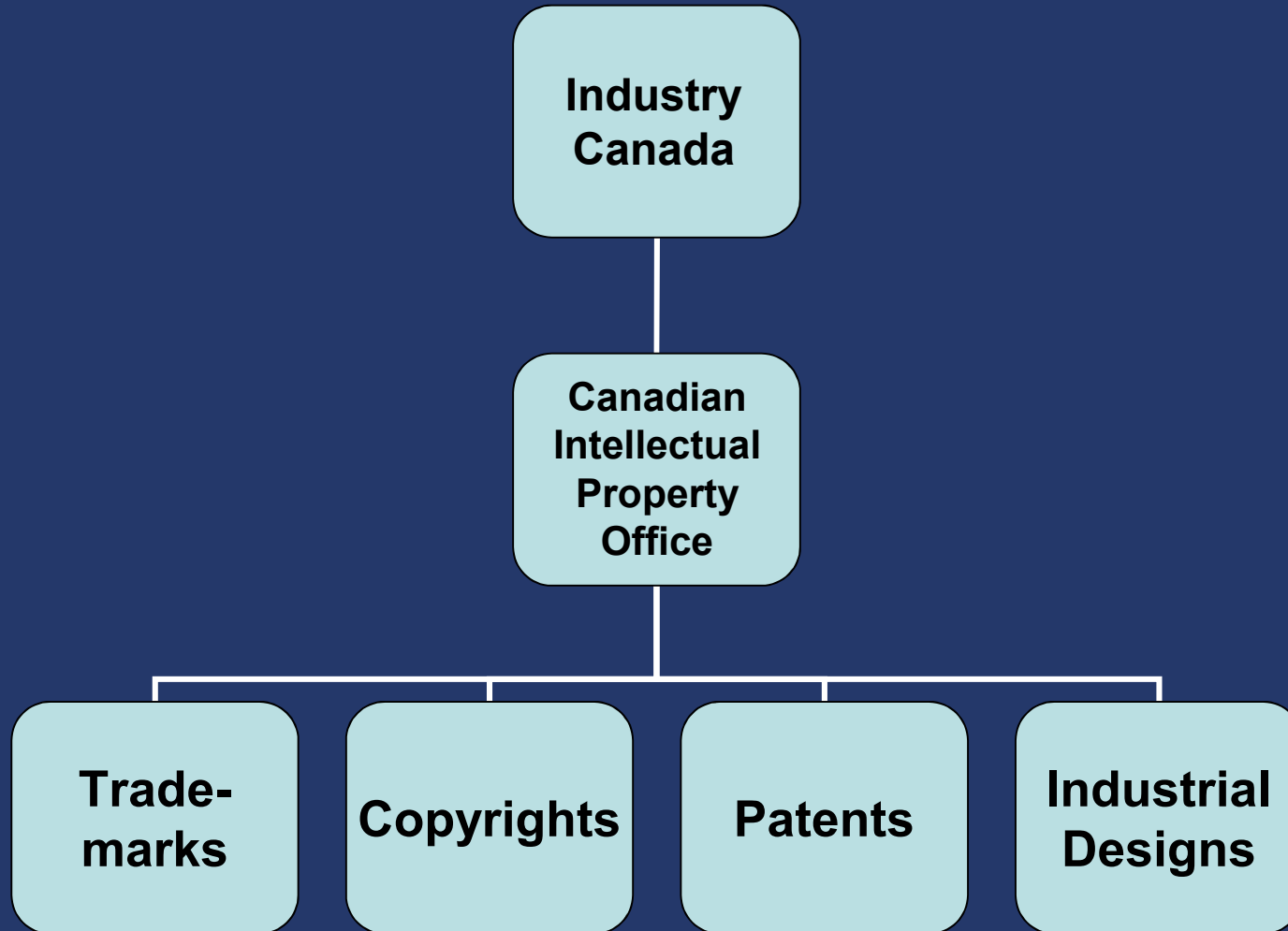

Go to: <http://www.cipo.ic.gc.ca> for more info.

# The *Trade-marks Act*



- A trade-mark is a word, symbol, or design that is used to distinguish the wares or services of a person or organization from those of others in the marketplace.

# Types of Trade-marks

1. Ordinary Mark: Word(s) or symbol(s) that distinguishes specific wares.



2. Distinguishing Guise: The shaping of wares or their containers, or a mode of wrapping or packing wares.



# Types of Trade-marks

3. Certification Mark: Identifies wares that meet a defined standard.



4. Trade Name: Name under which business is conducted. Can only be registered if it is also used to identify wares.

# Personal Names as Trade-marks



*Trade-marks Act* Section 12(1): “...a trade-mark is registrable if it is not...(a) a word that is primarily merely the name or the surname of an individual who is living or has died within the preceding thirty years...”

*BUT*: 12(2): “A trade-mark that is not registrable by reason of paragraph (1)(a)...is registrable if it has been so used in Canada by the applicant or his predecessor in title as to have become distinctive at the date of filing an application for its registration.”

# Examples of Personal Names as Trade-marks

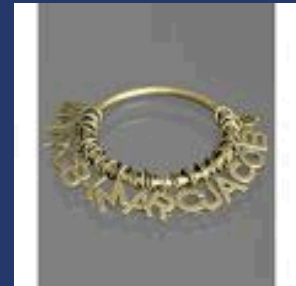
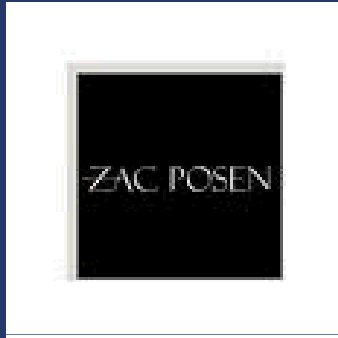

# Trade-mark Registration System



- Registration not required, but recommended.
  - Search for similar marks.
  - Register your trade mark with the Trade-marks Office.
  - Consider filing in other countries.
- Benefit of Registration = Exclusive rights to use the mark across Canada for 15 years, renewable every 15 years thereafter.

# Marking Your Trade-marks

® ≠ TM

- The ® symbol should be used only if the trade-mark is registered; the TM symbol may be used regardless of whether the trade-mark is registered or not.

# The *Copyright Act*

- Copyright subsists in all original literary, artistic, dramatic and musical works.
- Only a copyright owner may produce or reproduce work or permit anyone else to do so.
- No protection for ideas; work must be tangible.
- Protects artistic aspects of a product but not its functional features.



# The *Copyright Act*

- General rule for duration of copyright in Canada is that it lasts for 50 years after the death of the creator. In the United States and Europe, the term of copyright is longer.
- Registration not required, but recommended. Register your prints, designs, etc. with the Copyright Office.
- Mark as: “© Owner’s Name 2010. All rights reserved.”



# The *Industrial Design Act*

- An industrial design is the feature of shape, configuration, pattern, or ornament (or any combination thereof) applied to a finished article made by hand, tool, or machine.



# The *Industrial Design Act*

- Design must have features that:
  - (1) Appeal to the eye.
  - (2) Are original.
  - (3) Are not purely functional.

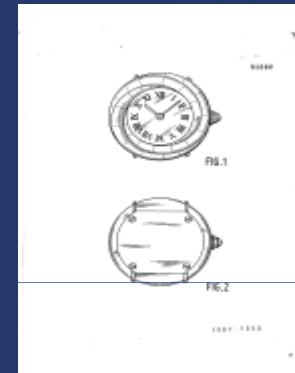
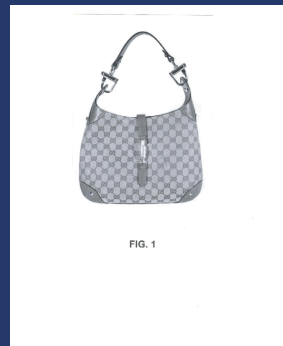

# Industrial Design Registration System

- Registration with the Industrial Design Office required within one year of publication of the design.
- Mark as: “  Proprietor Name.”
- Duration of registration = 10-year term, subject to the payment of maintenance fee 5 1/2 years from the date of registration.

# The *Patent Act*

- Patents cover new inventions (process, machine, manufacture, composition of matter), or any new and useful improvement of an existing invention.
- Registration with the Patent Office required.
- Duration of Registration = 20-year maximum.
- Mark as: “Patent No. \_\_\_\_\_,” “Patent applied for,” or “patent pending.”

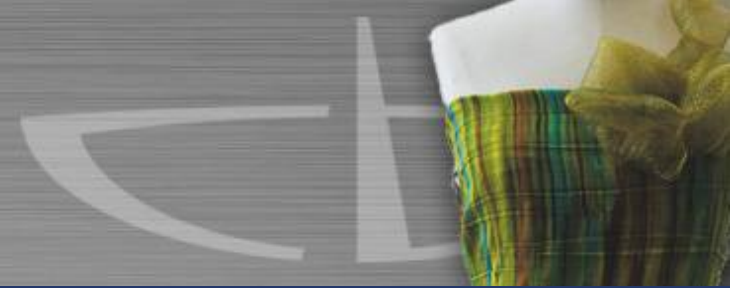

# 3 Basic Requirements for Patentability:



- Novelty: The invention must be new.
- Utility: The invention must be functional and operative; it must have a useful function.
- Ingenuity: The invention must show inventive ingenuity and not be obvious to someone skilled in a given area.

# Examples of Patents

## “No End Slimming Jeans”

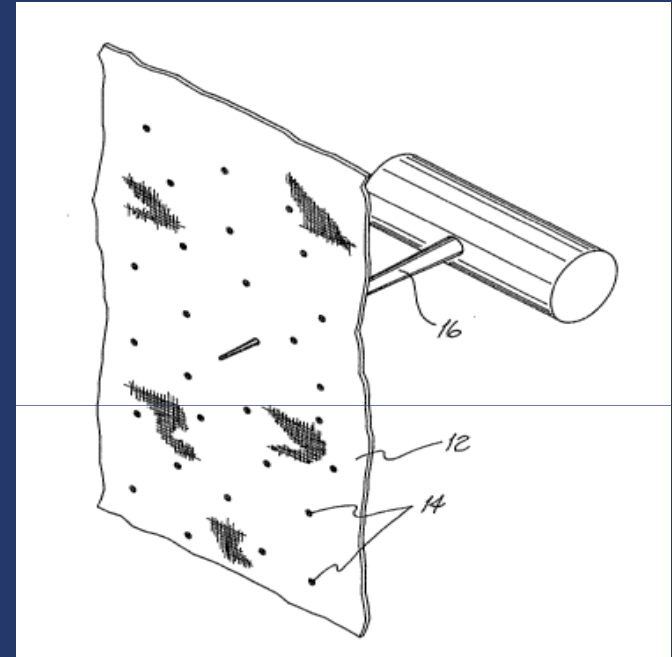
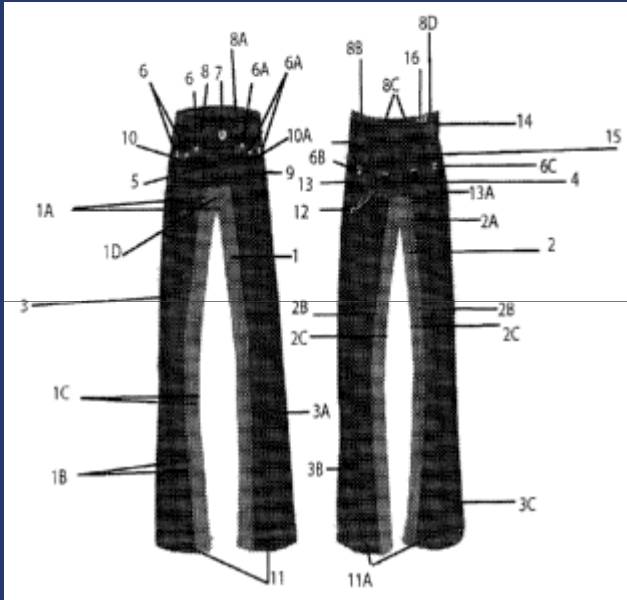

## “Method of Treatment for Denim Fabric”

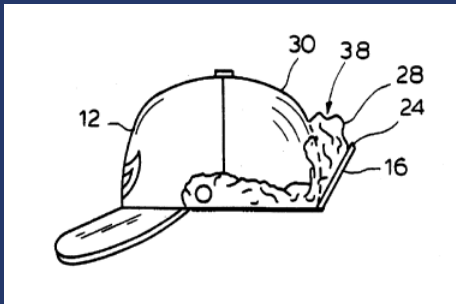

## “Hat in Combination with a Hood”

# Trade Dress



- “Trade dress” or “get-up” refers to characteristics of the visual appearance of a product or its packaging that signify to consumers the source of the product.
- This includes factors such as the appearance of product labels, packaging and containers, and product shape/configuration.

# Trade Secrets

- Trade secrets are commercially valuable proprietary information.
- Trade secrets law can be protected using the common law action for breach of confidence.



# Domain Names

- Domain names are usually made up of words that identify a company or describe the wares it provides.
- Domain names are an important part of online sale strategies.
  - Roots Canada: <http://canada.roots.com>
  - Skechers: <http://www.skechers.com>
- Problems with domain names include “cybersquatting,” registration of bad faith domain names, consumer confusion, and misdirected online traffic.
  - <http://www.louisvuittonlive.com>
  - <http://www.myguccistore.com>

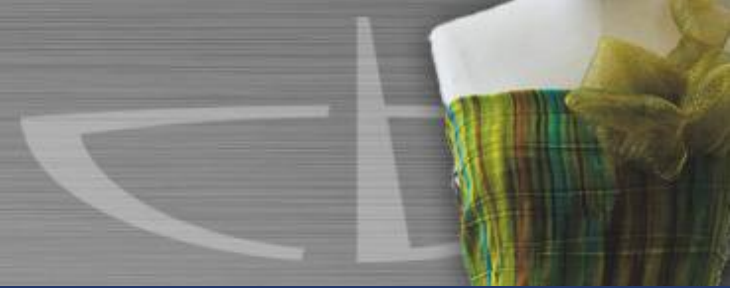

# Domain Names

- Register a domain name for your company even if you do not currently need a website.
- Monitor the internet regularly.
- Tools for enforcement of online rights:
  - ISP take-down requests.
  - Enforcement of copyrights or trade-mark rights in the courts.
  - CIRA's Dispute Resolution Policy, Dispute Resolution Rules, and Canadian Presence Requirements.
  - WHOIS Look-ups.



# Anti-Counterfeiting

- IP owner must take legal action himself or herself.
- Enforcement problems:



- RCMP's investigative priority is large-scale commercial infringement at the manufacturing, importation and wholesale distribution level.
- RCMP's anti-counterfeiting priorities are products with health and safety risks and links to organized crime, not counterfeit apparel.
- CBSA customs officers have no authority to seize or destroy counterfeit goods ex officio, but only to detain goods.
- Minimal fines and penalties generally awarded by courts.  
*Ex. Louis Vuitton Malletier S.A. v. 486353 B.C. Ltd.*

# Canada's Failures

- 2009: United States Trade Representative elevates Canada to its Priority Watch List of countries that deny adequate and effective protection of intellectual property rights. The only other countries on the list are Russia and China.
- 2010: International Anti-Counterfeiting Coalition recommends that Canada remain on this list.

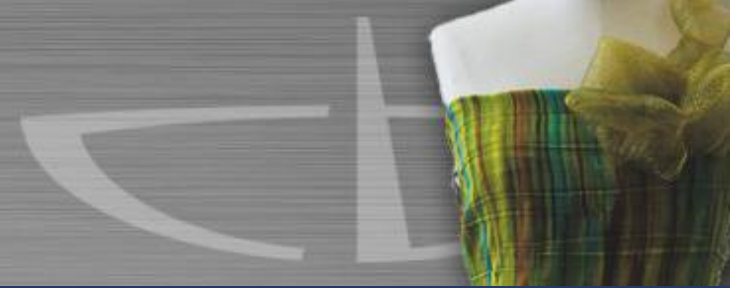

# Why?

- Need for substantive amendments to Canada's laws.
- Need for the application of greater political will in dealing with impediments to protection and enforcement of intellectual property rights.
- Reactive approach taken by Canadian authorities in response to trade-mark counterfeiting.

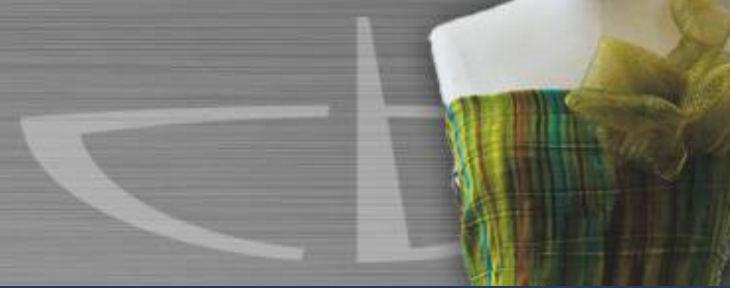

- 
- December 15, 2009 - March 15, 2010: Consultation period regarding changes to the *Trade-mark Act*.
  - May result in changes to Canada's trade-mark regime to align it with principles of international treaties such as the Madrid Protocol and the Singapore Treaty.

# *Design Piracy Prohibition Act*



- The *Design Piracy Prohibition Act* is a bill pending in the US Senate that would extend copyright protection to certain fashion designs for 3 years.
- "Trends" would be excluded from protection.
- Infringement would consist of copying the design without the consent of the owner.

# Other Strategies for Intellectual Property Protection

- Consider...
  - Using RFID and holographic tags.
  - Updating tags seasonally.
  - Distributing point of purchase counter cards and decals to stick in storefront windows of authorized retailers.





CASSELS BROCK  
LAWYERS



[www.casselsbrock.com](http://www.casselsbrock.com)

2100 Scotia Plaza, 40 King Street West, Toronto, Canada M5H 3C2 Phone 416 869 5300

© 2010 Cassels Brock & Blackwell LLP. Cassels Brock and the CB logo are registered trade-marks of Cassels Brock & Blackwell LLP. All rights reserved.